

Xtend 7818J Series

Assembly Instructions

Table of Parts

REF Part Name

A	Pole Cap (part of Pole Assembly)
B	VESA Plate
C	Extension Arm Assembly
D	Base Assembly
E	Set Screw
F	Lower Clamp Bracket
G	Clamp Bolt
H	Upper Clamp Bracket
I	Grommet Mount Bolt
J	Joint Cap
K	Height Adjust Arm Cable Manager
L	Clamp Knob
M	Clamp Pad
N	Fixed Arm Cable Manager
O	Clamp Pad Screw

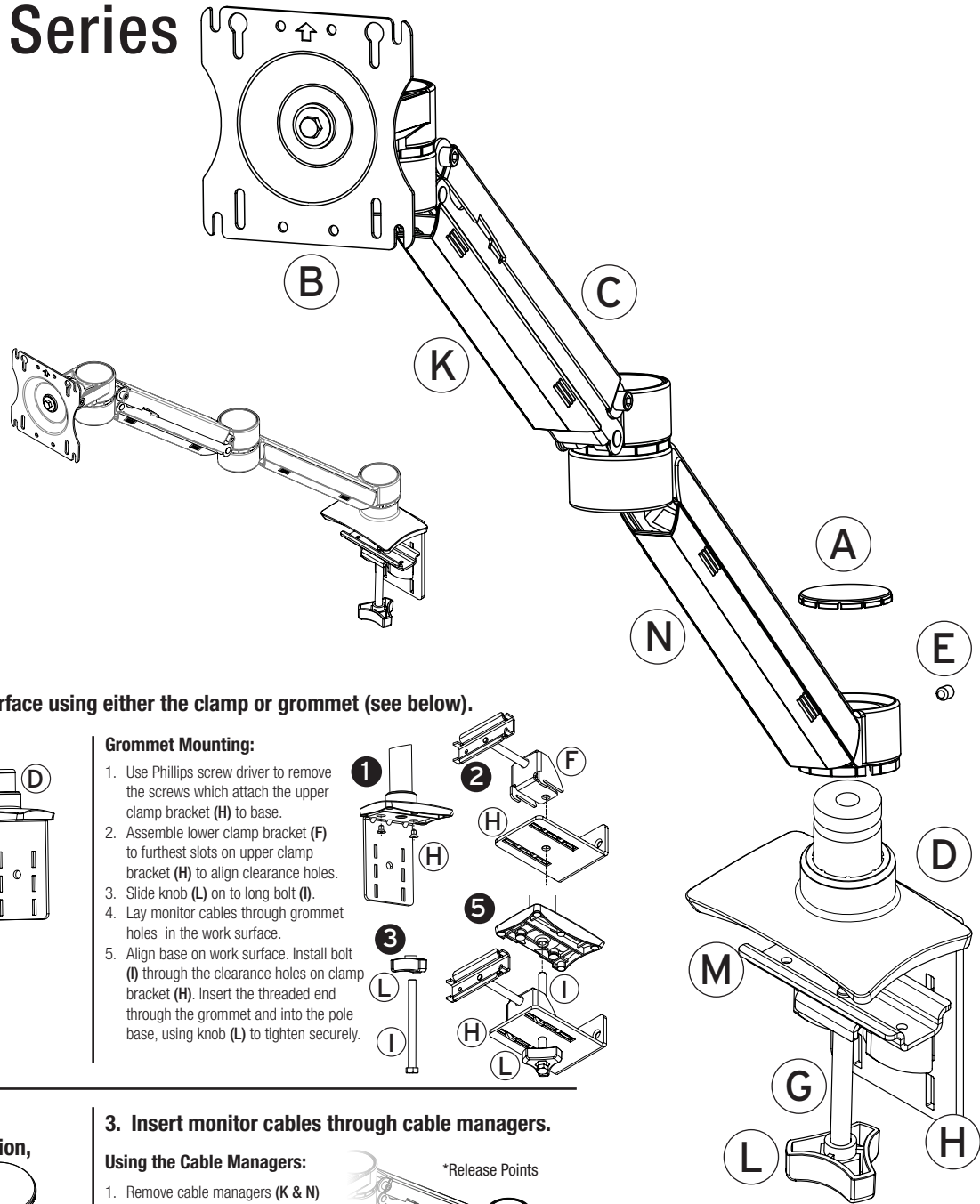

1. Mount base assembly (D) to work surface using either the clamp or grommet (see below).

Mounting base to work surface using the Clamp Mounting System:

- Slide knob (L) on to bolt (G), ensuring the bolt head is securely engaged into the knob.
- Screw bolt (G) in to the lower clamp bracket (F) and using clamp pad screw (O) attach clamp pad (M) to the end of the bolt (G).
- Hook lower clamp bracket (F) in to one of the top 2 (of the 3) positions provided.
- Position clamp bracket and base (D) onto work surface in desired location.
- Using knob (L) tighten securely.

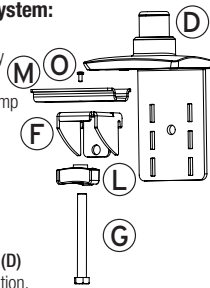

Grommet Mounting:

- Use Phillips screw driver to remove the screws which attach the upper clamp bracket (H) to base.
- Assemble lower clamp bracket (F) to furthest slots on upper clamp bracket (H) to align clearance holes.
- Slide knob (L) on to long bolt (I).
- Lay monitor cables through grommet holes in the work surface.
- Align base on work surface. Install bolt (I) through the clearance holes on clamp bracket (H). Insert the threaded end through the grommet and into the pole base, using knob (L) to tighten securely.

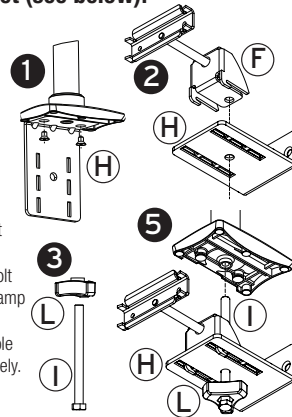

2. Mount arm assembly (C) to base and tighten set screw (E) for correct tension, followed by pole cap (A).

Assembling Xtend Arm onto base:

- Align bushing gaps to be perpendicular with set screw before tightening.

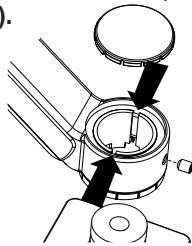

3. Insert monitor cables through cable managers.

Using the Cable Managers:

- Remove cable managers (K & N) by pinching at release points.
- Lay cables in cable managers. Make sure to leave enough slack at every joint and base.
- Snap cable managers back into place. Note text indication "TOP" inside cable manager.

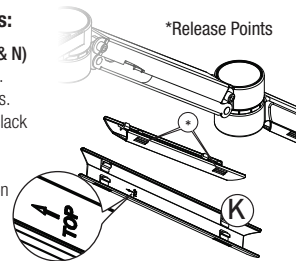

4. Mount monitor onto VESA Plate (B) using appropriate length screws provided.

5. Fine adjustments to the arm (optional).

Adjusting the Xtend Arm:

- With the monitor mounted to the arm, move the monitor through the height range; Ensure the arm will hold the monitor in the position you placed it.
- If the monitor drops or rebounds upward, adjust the tension screws at the front and back of the arm segment as shown using the 3/16" Allen key. Repeat steps until the monitor is counterbalanced.

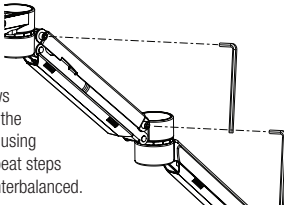

Adjusting the Joint Torque:

- Remove joint cap (J) from the top of the joint using a small flat head screw driver.
- Holding the bolt in the top of the joint with a 9/16" socket, use a second 9/16" socket on the nut in the bottom of the joint to adjust the torque setting.

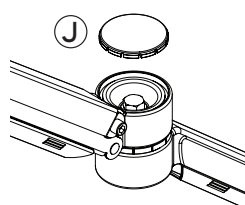

Adjusting the Tilt Tension

- If the monitor drops or is too tight, adjust the tension screw at the side of the head as shown using the 3/16" Allen key.

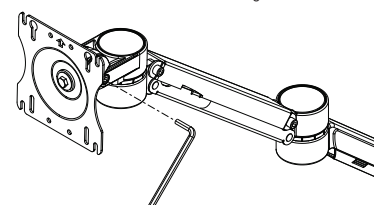

Dual Xtend 7822J

Assembly Instructions

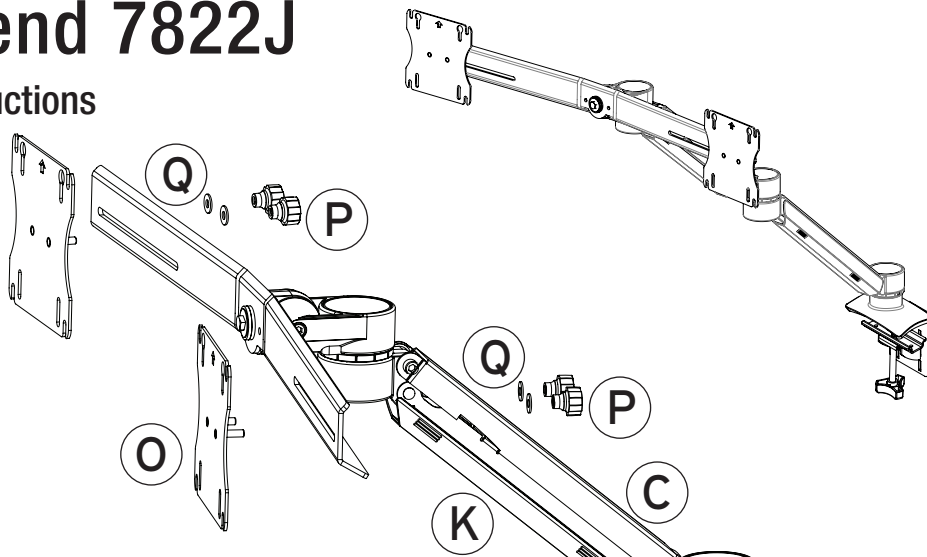

Table of Parts

REF	Part Name
A	Pole Cap (part of Pole Assembly)
B	VESA Plate
C	Extension Arm Assembly
D	Base Assembly
E	Set Screw
F	Lower Clamp Bracket
G	Clamp Bolt
H	Upper Clamp Bracket
I	Grommet Mount Bolt
J	Joint Cap
K	Height Adjust Arm Cable Manager
L	Clamp Knob
M	Clamp Pad
N	Fixed Arm Cable Manager
O	Face Plates
P	Thumb Knobs
Q	Washers
R	Spacers
S	Long Screws
T	Clamp Pad Screw

1. Mount base assembly (D) to work surface using either the clamp or grommet (see below).

Mounting base to work surface using the Clamp Mounting System:

- Slide knob (L) on to short bolt (G), ensuring the bolt head is securely engaged into the knob.
- Screw bolt (G) in to the lower clamp bracket (F) and using clamp pad screw (O) attach clamp pad (M) to the end of the bolt (G).
- Hook lower clamp bracket (F) in to one of the top 2 (of the 3) positions provided.
- Position clamp bracket and base (D) onto work surface in desired location.
- Using knob (L) tighten securely.

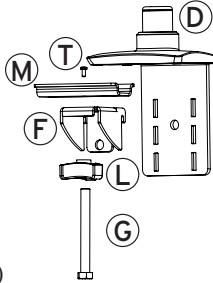

Grommet Mounting:

- Use Phillips screw driver to remove the screws which attach the upper clamp bracket (H) to mounting base.
- Assemble lower clamp bracket (F) to the furthest slots on upper clamp bracket (H) to align clearance holes.
- Slide knob (L) on to long bolt (I).
- Lay monitor cables through grommet holes in the work surface.
- Align base on work surface. Install bolt (I) through the clearance holes on clamp bracket (H). Insert the threaded end through the grommet and into the pole base, using knob (L) to tighten securely.

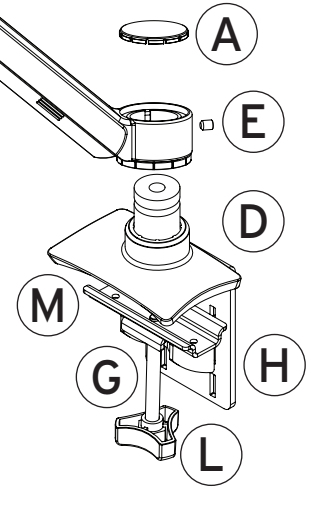
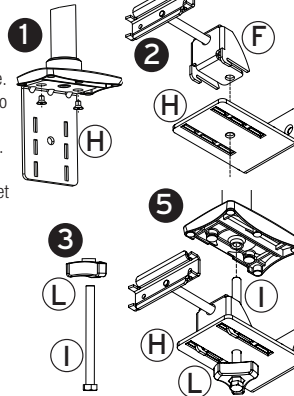

2. Mount arm assembly (C) to base and tighten set screw (E) for correct tension, followed by pole cap (A).

Assembling Dual Xtend Arm onto base:

- Align bushing gaps to be perpendicular with set screw before tightening.

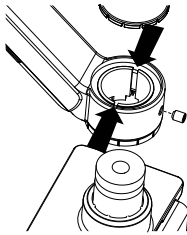

3. Insert monitor cables through cable managers.

Using the Cable Managers:

- Remove cable managers (K & N) by pinching at release points.
- Lay cables in cable managers. Make sure to leave enough slack at every joint and base.
- Snap cable managers back into place. Note text indication "TOP" inside cable manager.

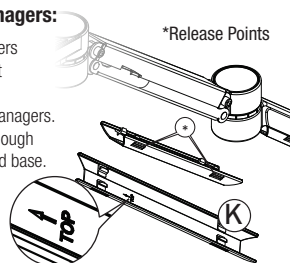

4. Mount monitor onto VESA Plate (O).

Attaching Monitors:

- Use appropriate length screw provided.
- If monitor has a recessed mounting surface, use spacers provided.

Attaching Face Plates:

- Attach face plates (O) using thumb knobs (P) and washers (Q) as shown. Adjust location of screens to desired location by loosening thumb knobs. Re-tighten when finished.

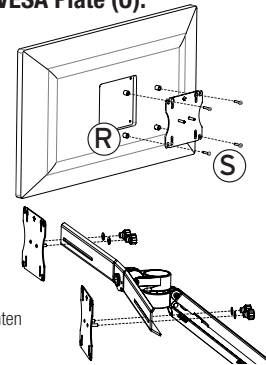

5. Fine adjustments to the arm (optional).

Adjusting the Xtend Arm:

- With the monitor mounted to the arm, move the monitor through the height range; Ensure the arm will hold the monitor in the position you placed it.
- If the monitor drops or rebounds upward, adjust the tension screws at the front and back of the arm segment as shown using the 3/16" Allen key. Repeat steps until the monitor is counterbalanced.

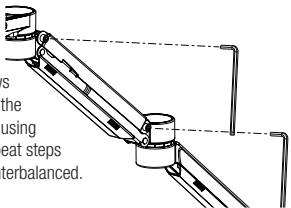

Adjusting the Joint Torque:

- Remove joint cap (J) from the top of the joint using a small flat head screw driver.
- Holding the bolt in the top of the joint with a 9/16" socket, use a second 9/16" socket on the nut in the bottom of the joint to adjust the torque setting.

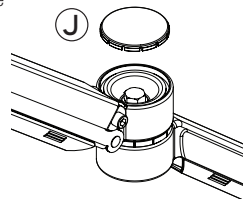

Adjusting the Tilt Tension

- If the monitor drops or is too tight, adjust the tension screw at the side of the head as shown using the 3/16" Allen key.

