

# Offices to Go

Height adjustable table  
Assembly Instructions

Table réglable en hauteur  
Instructions de montage

U.S.A.  
17 West Stow Road P.O. Box 562  
Marlton New Jersey U.S.A. 08053  
Tel (856) 596-3390 (800) 220-1900  
Fax (856) 596 5684

Canada  
1350 Flint Rd., Toronto ON Canada M3J 2J7 Sales &  
Marketing: Tel (1-877) 446-2251 Customer Service: Fax (800)  
361-3182 Government Customer Service: Fax (416) 739-6319

International  
560 Supertest Rd., Toronto ON Canada M3J 2M6 Tel (416)  
661-3660 (800) 668-5870  
Fax (416) 661-5671

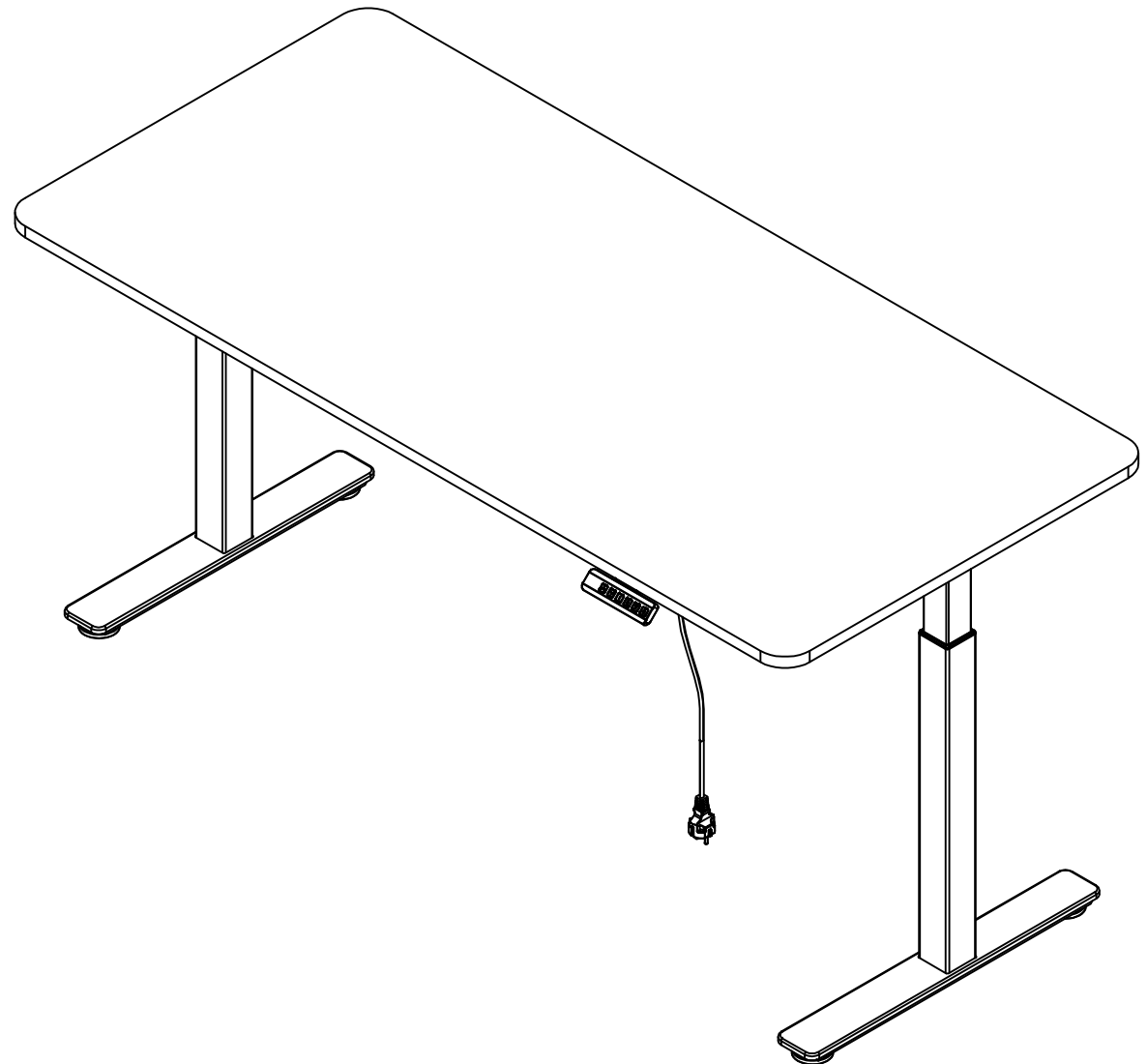



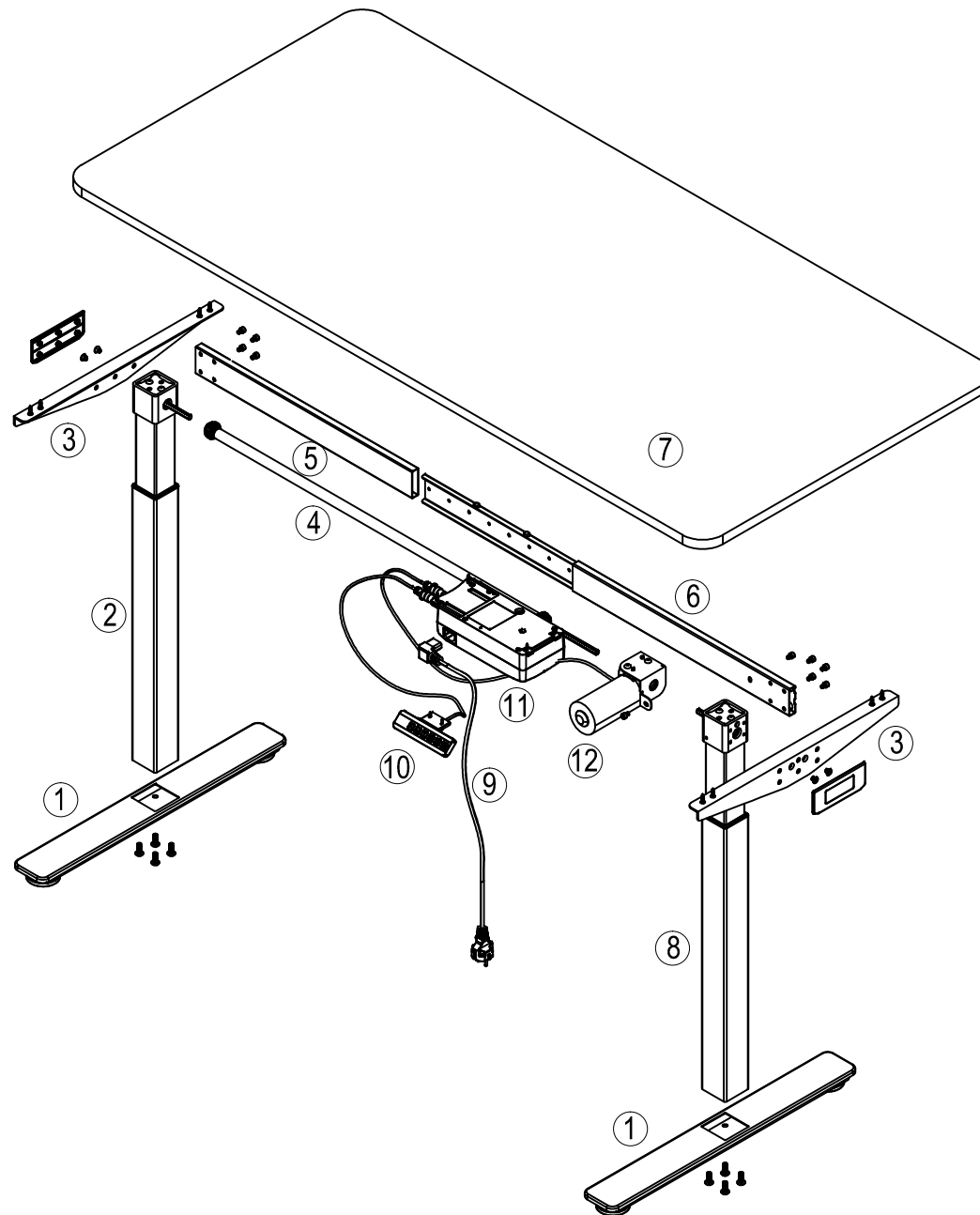







Printed in China / Imprimé en Chine . Revision  
05/07/19 . 00507 MLEBDD162

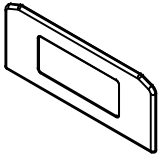

Hardware List: (included with product)

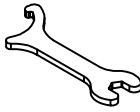
Liste du matériel: (inclus avec le produit)

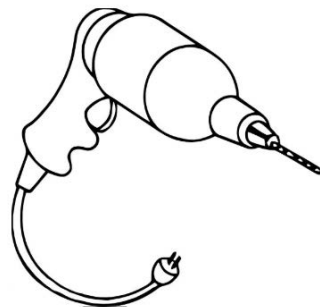

					
A x10 (M8x20)	B x12 (M6x8)	C x4 (M6x12)	D x10 (M6x10)	E x10 (ST4.8x20)	F x8 (ST3x19)
					
G x2	H x1 (4mm)	I x1 (5mm)	J x1	K x4	

Tools needed:  
Outils nécessaires:



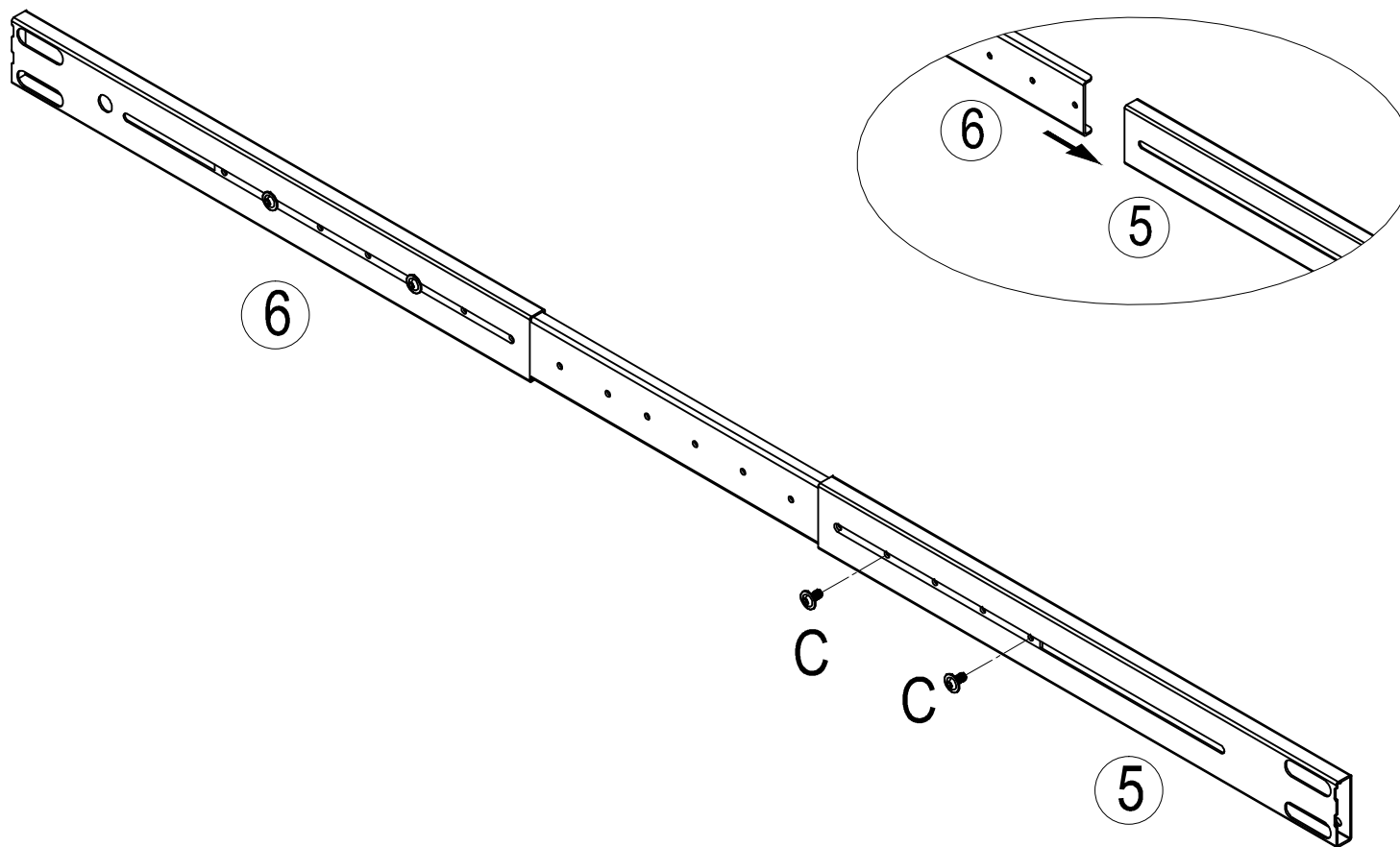

Step 1  
étape 1



	
H x1	C x2

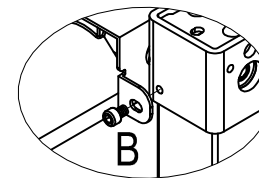
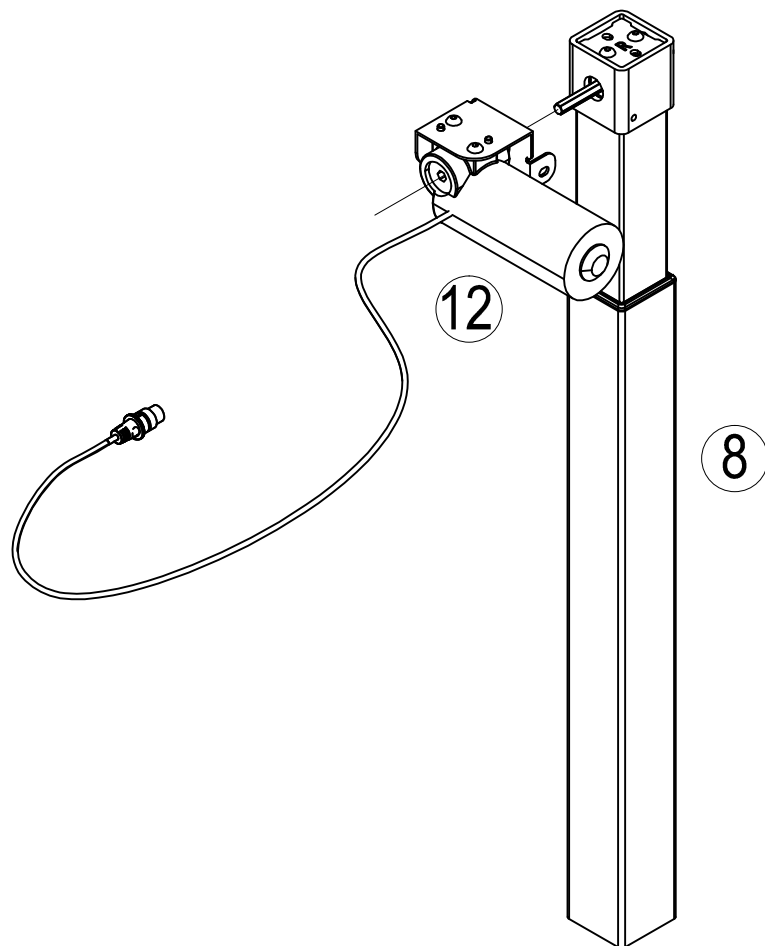

Step 2  
étape 2

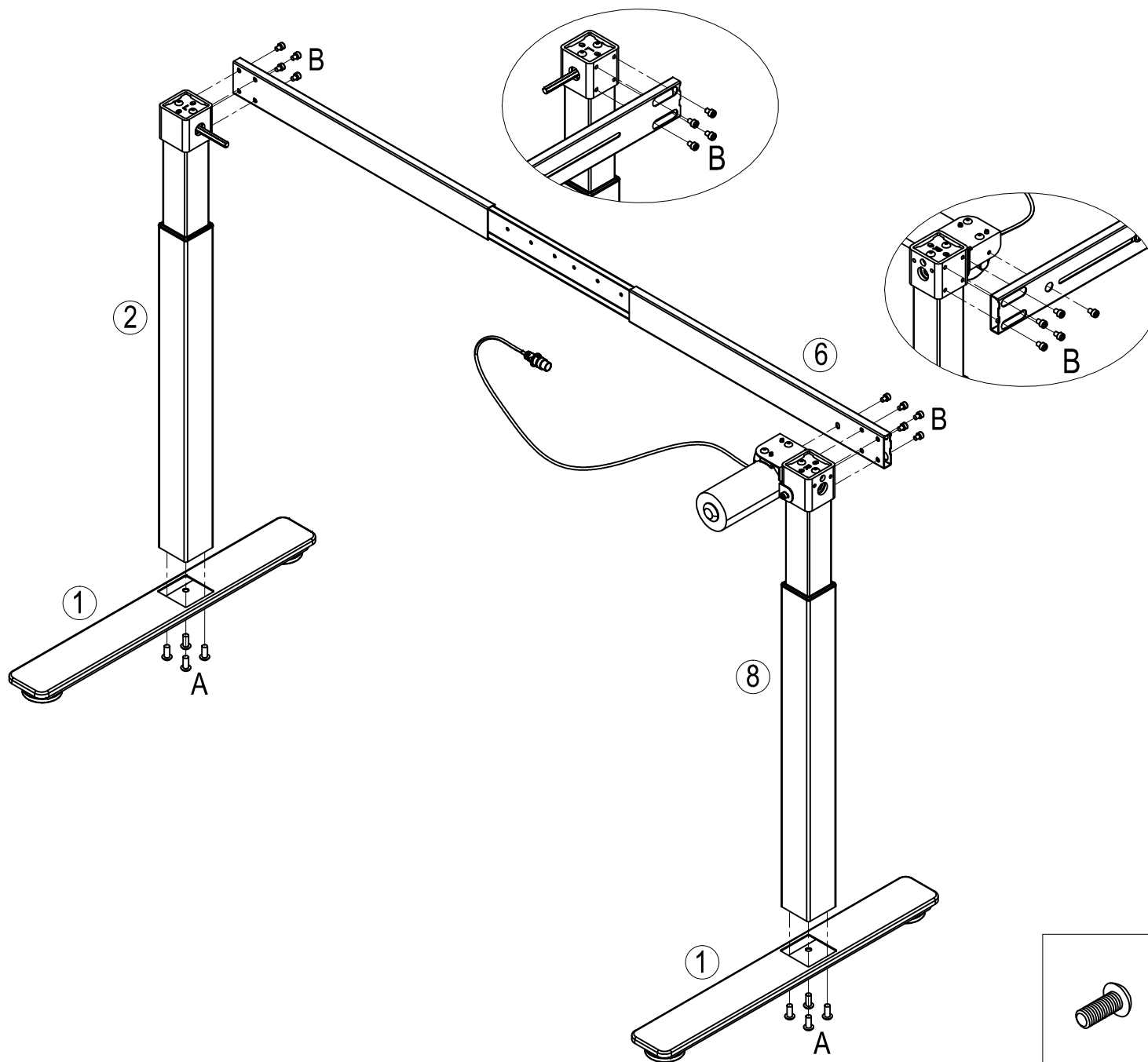

	
B x1	I x1

Step 3  
étape 3



		
A x8	B x9	I x1



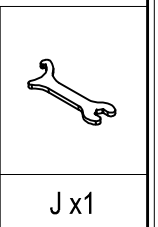
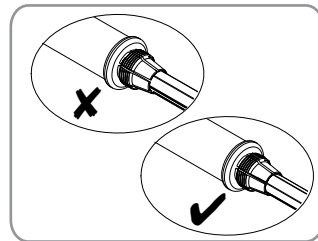
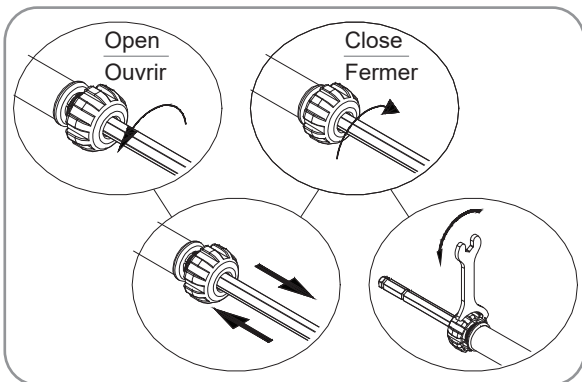
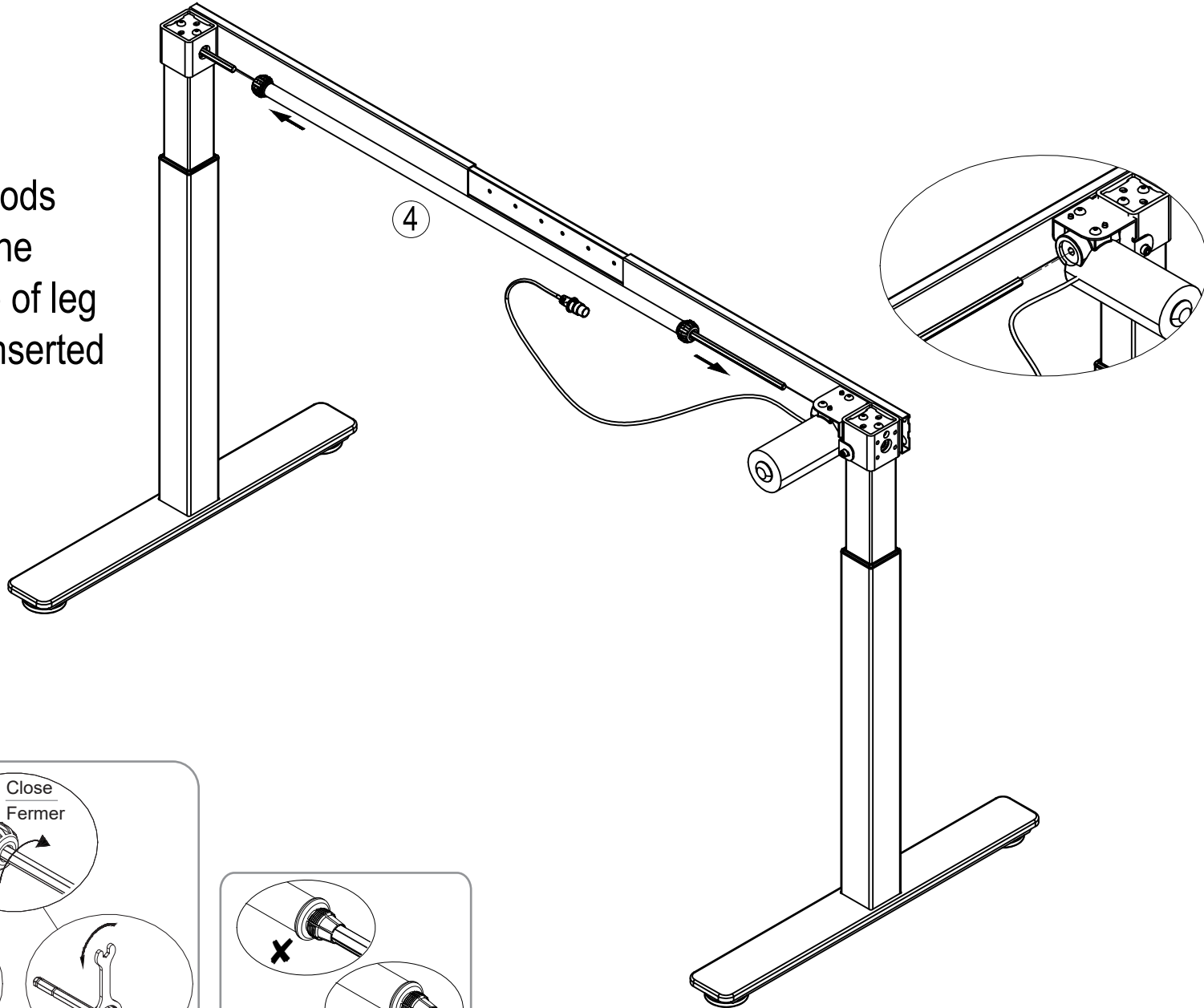

Step 4  
étape 4

Ensure hex rods are flush to the outside edge of leg posts once inserted

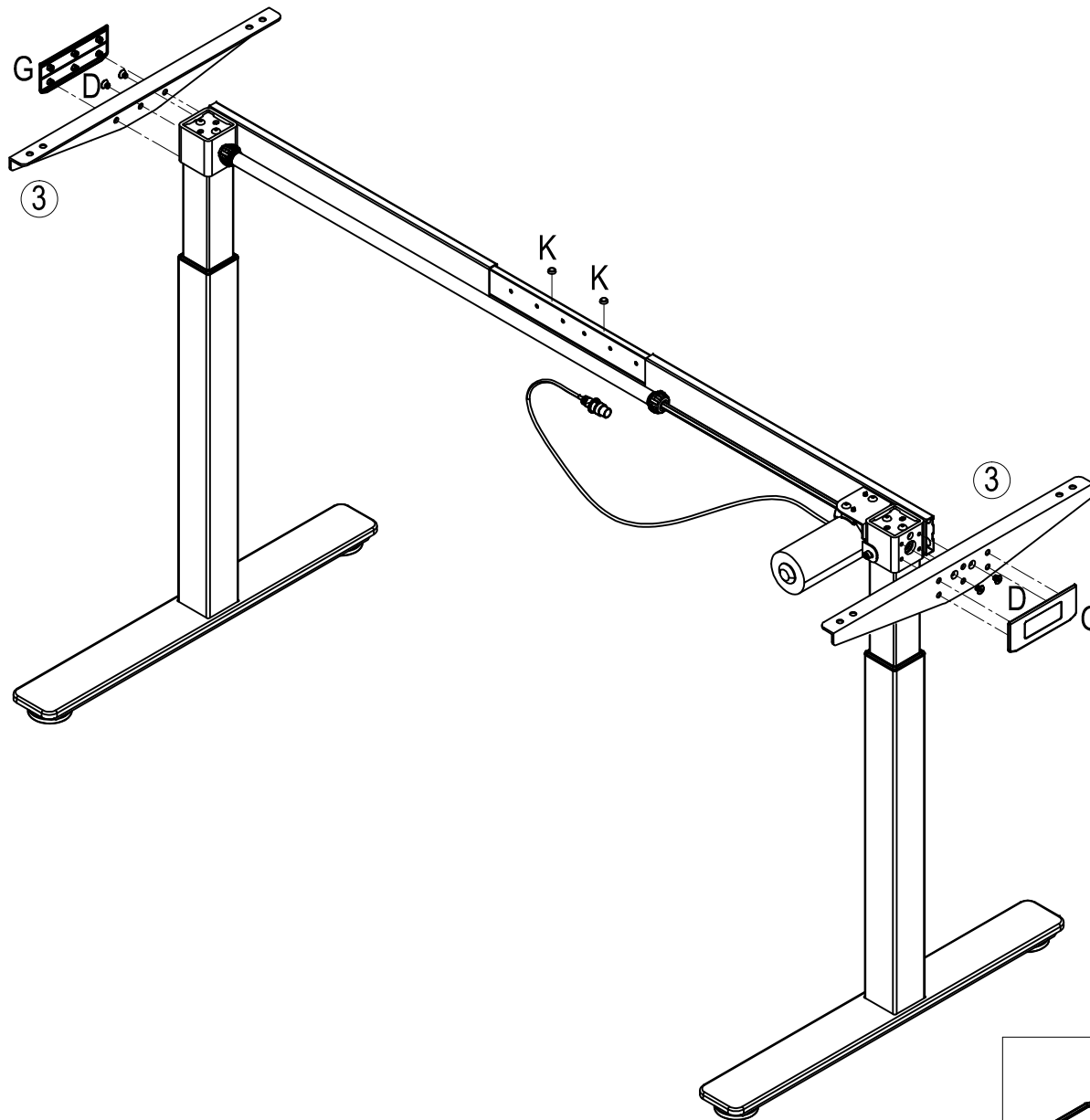

Step 5  
étape 5

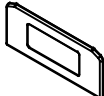

			
H x1	D x4	G x2	K x2

Step 6  
étape 6



Optional: While wood screws are self tapping, it is optional to first add pilot holes once the base is centered on the top before screwing base to top(E). With the base positioned on the top, using drill place drill bit of smaller diameter than screw in positions marked E and make a small pilot hole in each location for screw. Pilot holes should only be deep enough to penetrate the laminate surface, do not exceed 8mm. Use wood screws to then secure top to the base.

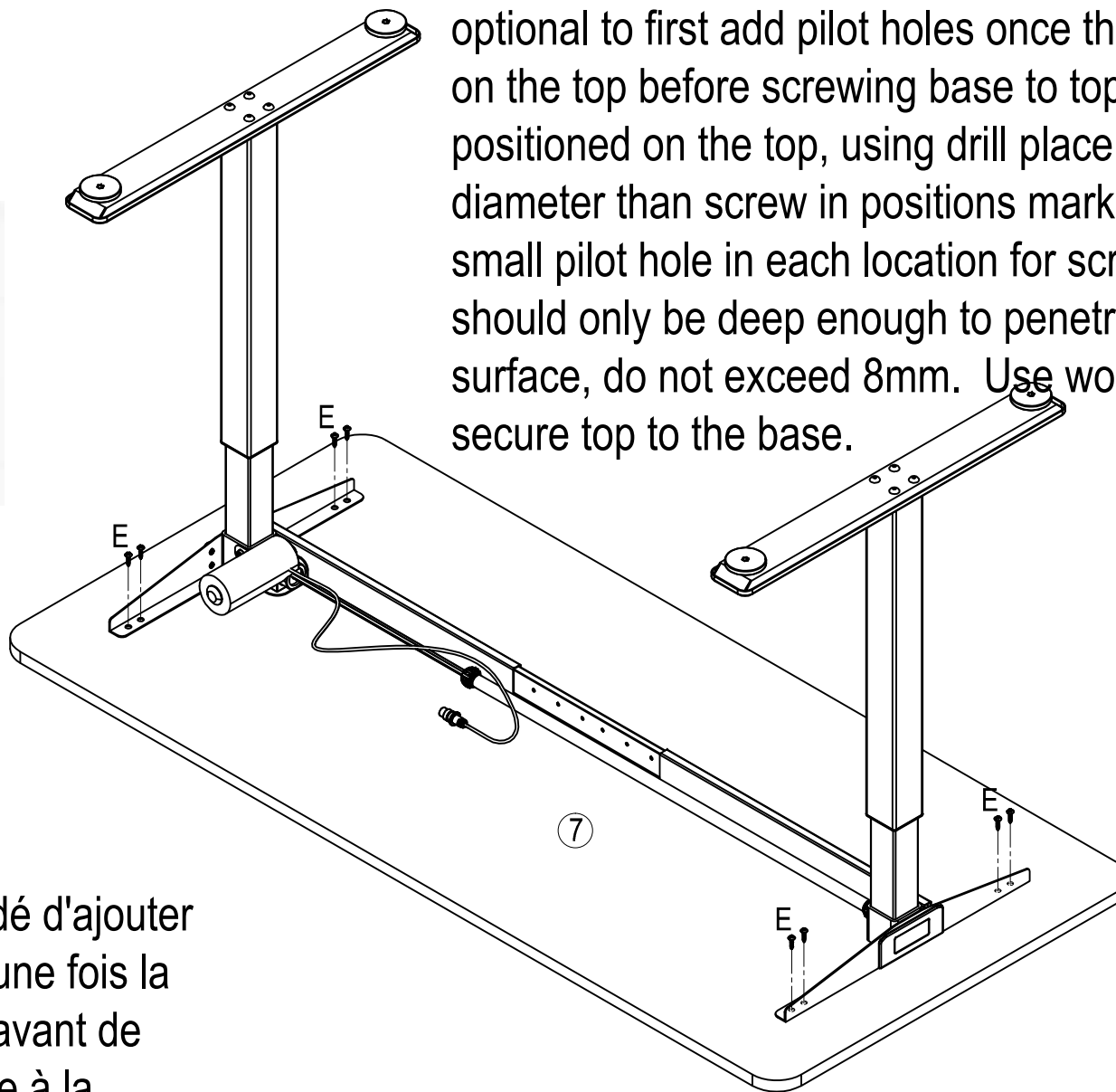

Il est recommandé d'ajouter des avant-trous une fois la surface centrée avant de connecter la base à la surface.

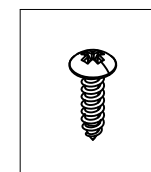

E x 8

Step 7  
étape 7

